

# C-SERIES Dimensions

## CLSX - 1.5, 2, 2.5, 3, 3.5, 4, 5 Ton

# Marc Climatic Controls, Inc.

5-23-07

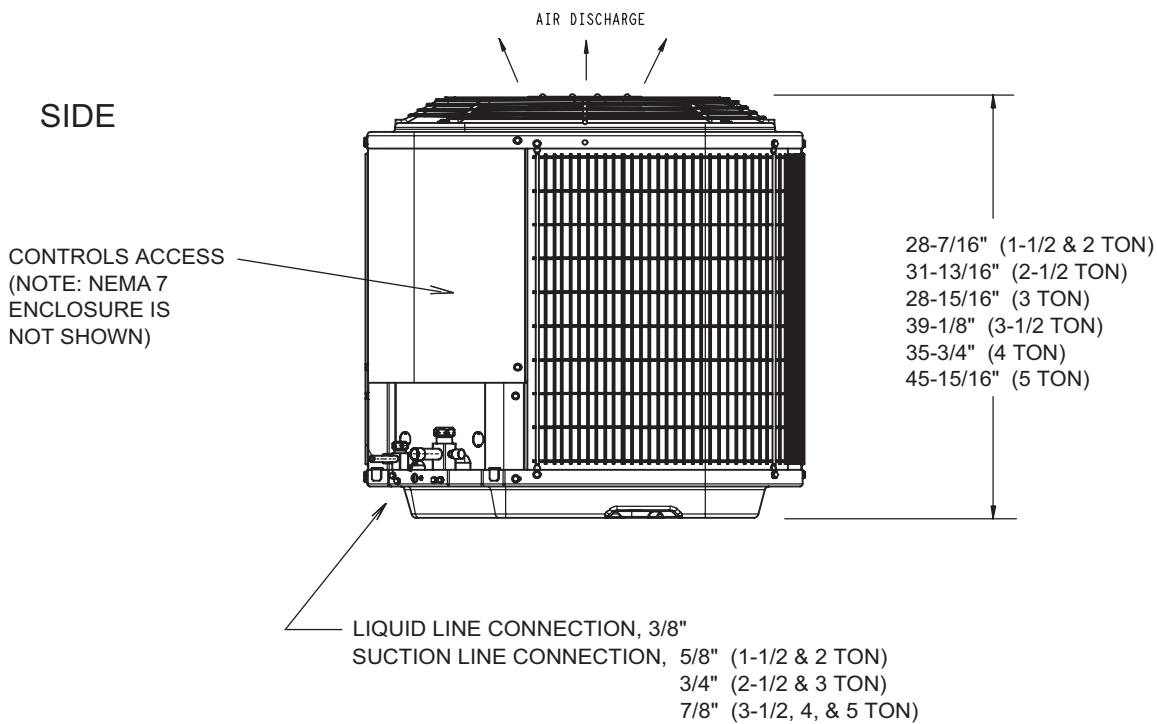
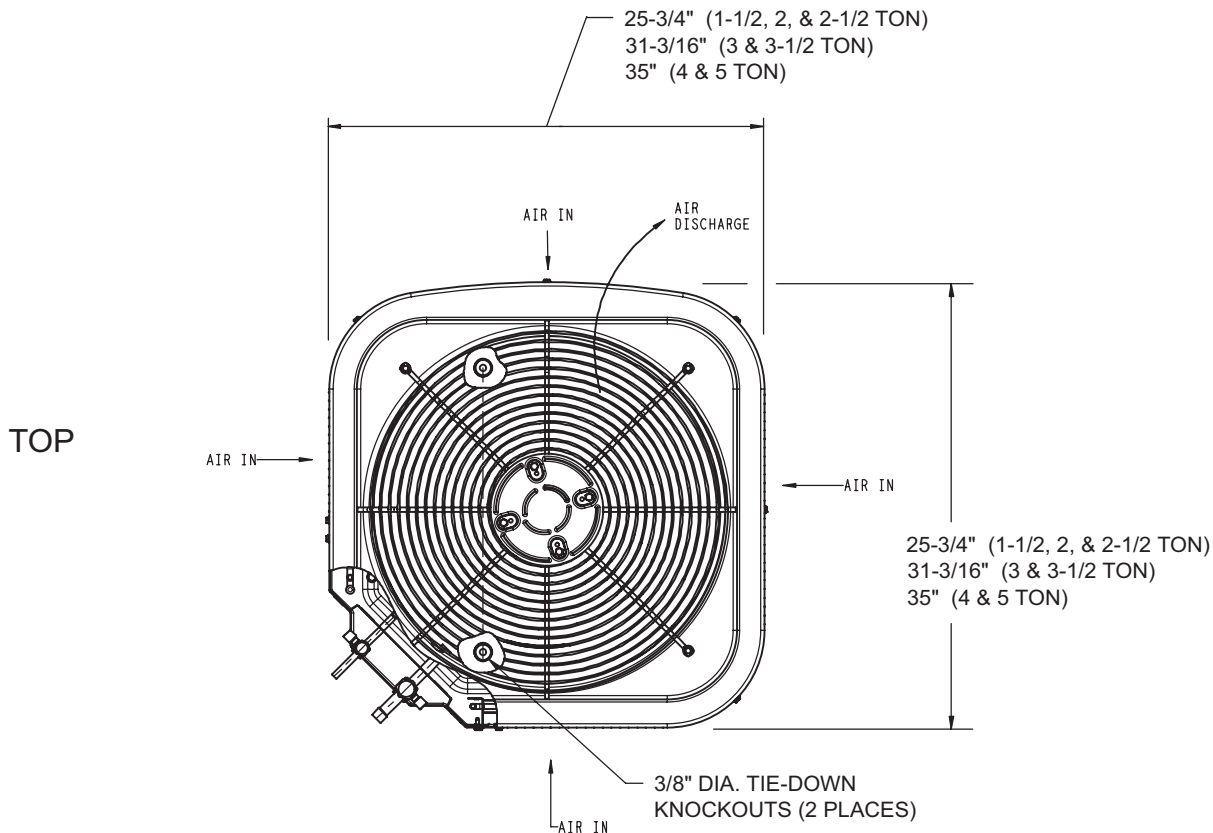

# C-SERIES Dimensions CLSX 6, 7.5, & 10 Ton

# Marc Climatic Controls, Inc.

5-23-07

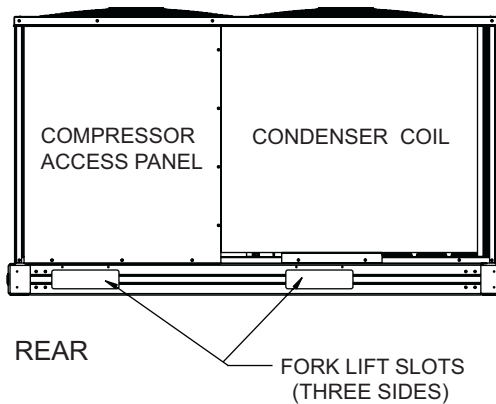
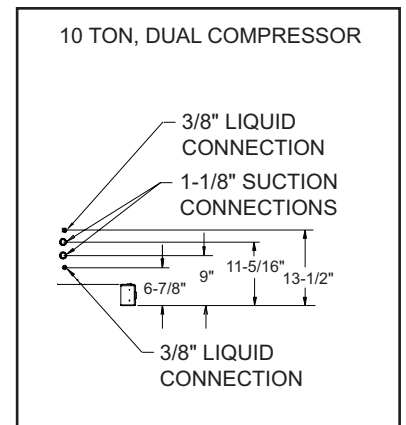
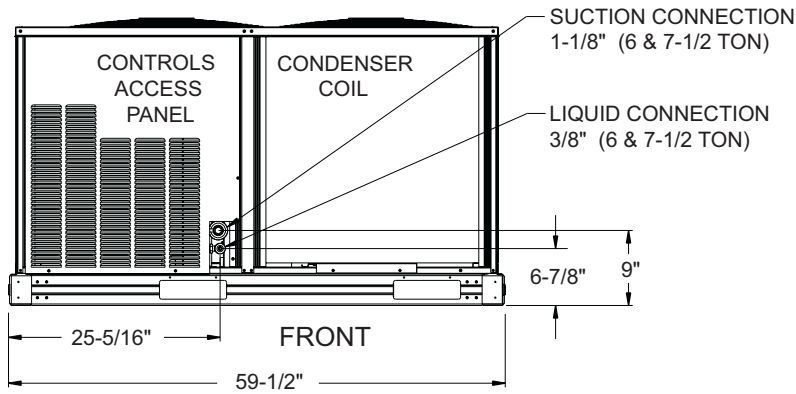
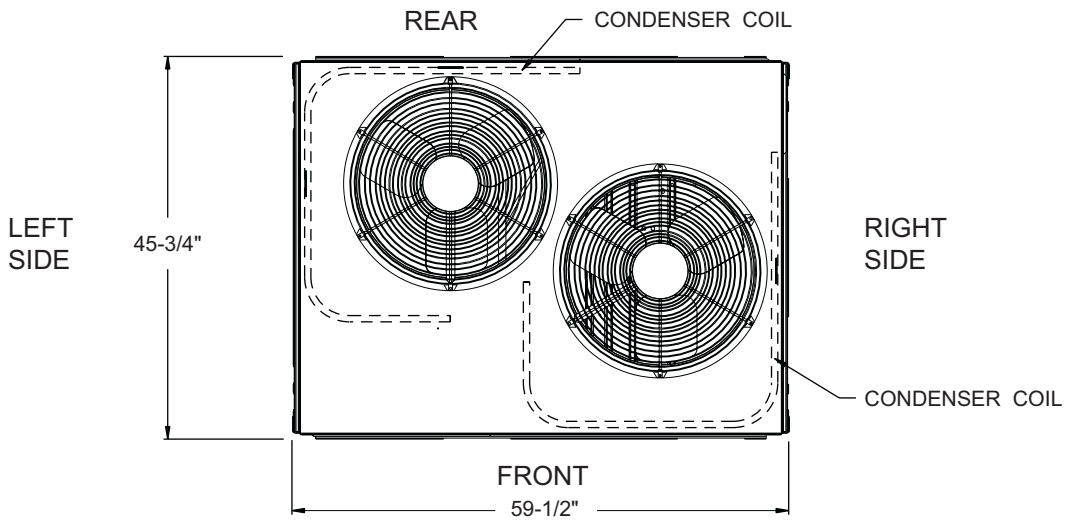

NOTE: NEMA 7 ENCLOSURE IS NOT SHOWN

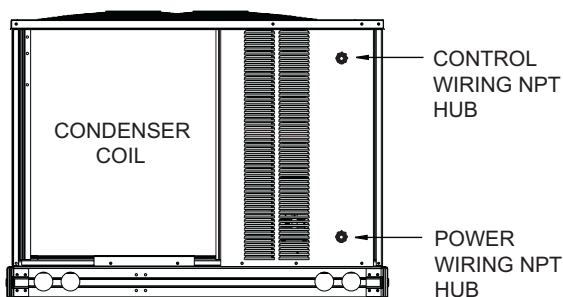

LEFT SIDE

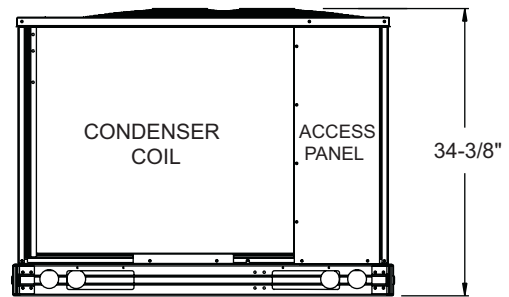

RIGHT SIDE

# C-SERIES Dimensions CLSX 12.5, 15, & 20 Ton

Marc Climatic Controls, Inc.

5-24-07

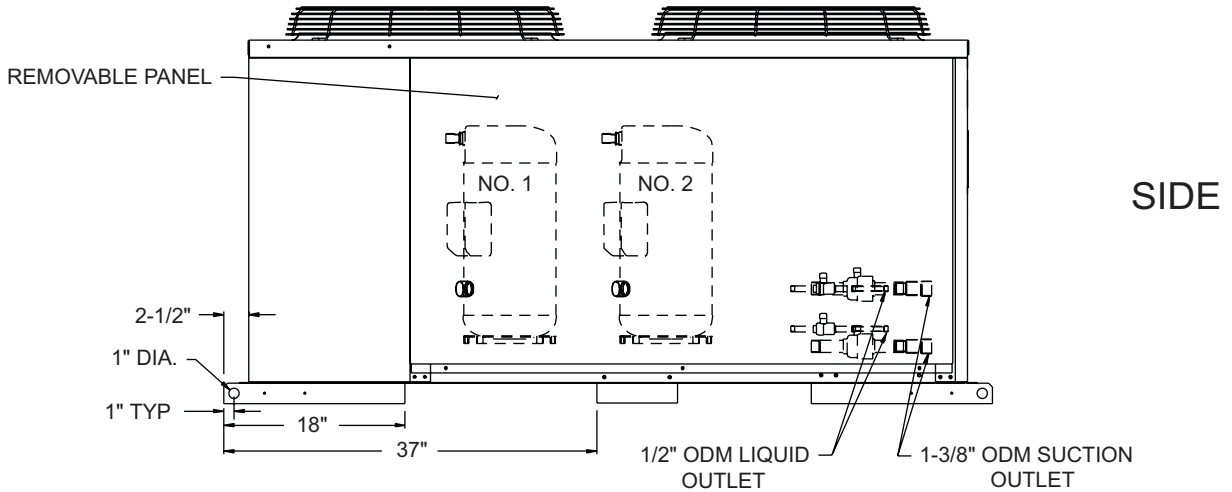
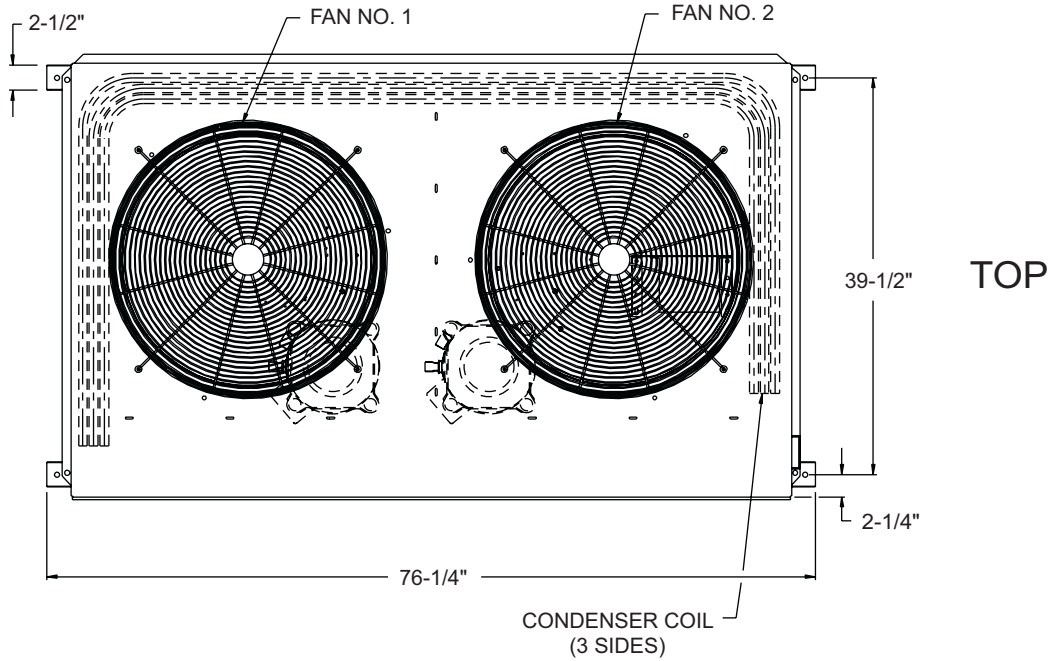

NOTE: NEMA 7 ENCLOSURE IS NOT SHOWN

